

# HIRAYAMA

No. TA96F007

AUTOMATIC HIGH PRESSURE AUTOCLAVE

## HICLAVE

HV-25

HV-50

HV-85

HV-110

### OPERATION MANUAL

- If you handle this autoclave in the same way as ordinary gas instruments or electrical appliances, accidents may occur. Be sure to read this instruction manual carefully and handle it properly.

## Introduction

---

- We would like to express our gratitude for your purchase of our autoclave. This brochure covers the operation method and a simple maintenance method for the Autoclave **HV-25/50/85/110** you now own. We hope that owing to your proper handling the autoclave can demonstrate its full performance and that you will make regular use of it for a long time.
- For optional equipment ( printer,  floating sensor,  cooling fan,  automatic water supply equipment), if any, read the attached operation manuals for the equipment.
- Please check whether or not the product conforms to your order and confirm that it was not damaged during transportation. Should it be damaged or out of order, please contact the sales outlet from which you purchased it.
- Be sure to send the enclosed warranty registration card to us.

(1) No part of this document may be reproduced without permission.  
(2) The contents of this document are subject to change without notice.  
(3) This document has been carefully compiled. If you have any questions or necessary information uncovered in the document, please contact us or the sales outlet from which you purchased the product.

## Table of Contents

---

No.	Date	Description of Revision
1	Jun. 11, 1996	Additions and revisions to WARNING, CAUTION and NOTE. Instructions under "Replacing Lid Packing" in Chapter 4: Maintenance and Service revised. Instructions for "Operation with a Waste Disposal Bag" added. Instructions for "Successive Operations with the Product" added.

## Before Using

---

- In this manual the following headwords are applied to items to which great attention should be given:

 **WARNING:** Precaution indicating an imminent dangerous situation which if not avoided may lead to death or serious injury.

 **CAUTION:** Precaution indicating a dangerous situation which if not avoided may lead to moderate or slight injury.

 **IMPORTANT:** Indicates items you are strongly advised to obey.

 **NOTE:** Items you should pay attention to during operation.

### **WARNING**

- Never use the autoclave to sterilize the following dangerous objects or substances containing alkali content. Sterilization of such objects may cause explosion, corrosion of the working chamber or piping, and deterioration in packing.

#### List of Dangerous Objects:

##### (1) Explosive substances

- Nitroglycol, nitroglycerin, nitrocellulose, and other explosive nitric esters.
- Trinitrobenzene, trinitrotoluene, picric acid, and other explosive nitro compounds.
- Peracetic acid, methyl ethyl ketone peroxide, benzoyl peroxide, and other organic peroxides.

##### (2) Ignitable substances

- Metallic lithium, potassium, sodium, yellow phosphorous, phosphorus sulfide, and red phosphorus
- Celluloids, calcium carbide (carbide), lime phosphide, and magnesium powder
- Aluminum powder, magnesium powder, and metallic powders other than aluminum powder
- Sodium dithionite (or sodium hydrosulfite)

##### (3) Oxidizer

- Potassium chlorate, sodium chlorate, ammonium chlorate, and other chlorates
- Potassium perchlorate, sodium perchlorate, ammonium perchlorate, and other perchlorates.
- Potassium peroxide, sodium peroxide, barium peroxide, and other inorganic peroxides
- Potassium nitrate, sodium nitrate, ammonium nitrate, and other nitrates
- Sodium chlorite and other chlorites
- Calcium hypochlorite and other hypochlorites

##### (4) Inflammable substances

- Ethyl ether, gasoline, acetaldehyde, propylene oxide, carbon disulfide, and other substances whose flash points range from  $-30^{\circ}\text{C}$  to  $0^{\circ}\text{C}$  exclusive.
- Methanol, ethanol, xylene, benzyl acetate (or amyl acetate), and other substances whose flash points range from  $0^{\circ}\text{C}$  to  $30^{\circ}\text{C}$  exclusive.
- Kerosene, gas oil, turpenine oil, isopentyl alcohol (or isoamyl alcohol), acetic acid, and other substances whose flash points range from  $30^{\circ}\text{C}$  to  $65^{\circ}\text{C}$  exclusive.

(5) Flammable gas (hydrogen, acetylene, ethylene, methane, ethane, propane, butane, and other substances that are gas at a temperature of 15°C at 1 atmospheric pressure.)

- Before opening the lid, be sure to check that the pressure gauge reads "0 kgf/cm<sup>2</sup>".

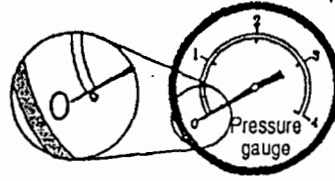

- Never modify the product.

**⚠ CAUTION**

- Foreign matter (metals, liquid) may enter through the vent hole. Operating the equipment with such foreign matter inside may cause trouble with the equipment, fire and electric shock.
- Do not forcibly bend, twist, tie or extend the power cord. Do not place heavy objects on the cord. A damaged cord or exposed wire may cause fire or electric shock.
- Never connect the power cord to a power supply other than the voltage that is rated. Connection to such a power supply may cause fire or electric shock.
- If not plugging the sterilizer into a grounded socket, ground the equipment separately before connecting it to a power source.
- Never ground to a gas pipe or vinyl chloride water service pipe.
- Before closing the lid, check to see that there are no foreign matters in the portion of the lid which is in contact with the lid packing. Foreign matters may cause steam leakage.
- Whenever a bag, such as a waste disposal bag, is used for sterilization, put it in the wire mesh basket and place the basket in the working chamber. If the bag is placed directly in the working chamber, the piping may become clogged by it and overheating, overpressurization, and/or lack of water may result.
- Be careful not to pinch hands when closing the lid.
- Do not put your face or hands close to the working chamber when lifting the lid after operations are complete; steam will gush out of the opening of the chamber.
- The lid, working chamber, packing and panel are extremely hot immediately after the completion of operation. Do not touch the equipment or you may get burned.
- Put on heat insulation gloves before removing a substance from the working chamber. Do not put your hands into the chamber until the steam has been vented.
- It takes a lot of time for the liquid to cool. Be sure to check that the temperature has dropped sufficiently before unloading the liquid from the working chamber, or you may get burned.

- Do not unload the exhaust bottle or drain the working chamber when the chamber is under pressure. Boiling water or steam may gush out, and you may get burned.
- Do not unload the exhaust bottle before water in the bottle has been sufficiently cooled.
- Do not dispose of used batteries in fire; they may explode.
- If you encounter any anomaly (e.g. abnormal sound and smell, smoking), immediately shut off power. After checking to see that the abnormal condition is not continuing, call us or our authorized sales outlet from which you purchased it.
- If the display differs between the steps, turn off the POWER switch, and then turn the power on again. If the condition still remains, turn off the power and call us or our authorized sales outlet from which you purchased it.
- If the equipment is installed in a place which is 800 m or higher than sea level (i.e. under low pressure in mountain areas), the over pressure preventive device and the air vent device require changes to their setting. In this case, be sure to contact us. Do not use the equipment before changing the setting.
- In transporting the equipment, put the lid on and slide the open/close lever to the end of the close side to prevent the lid from opening.
- When moving the lid, do not hold it by the handle, otherwise the lid may become difficult to close.

## **How to Read This Manual**

---

- This operation manual consists of the following sections covering the information required for proper operation of the autoclave **HV-25/50/85/110**:

### **Chapter 1. What Is Autoclave HV-25/50/85/110?"**

This section describes the uses and features of the product and the names and functions of its parts.

### **Chapter 2. Installation**

This section explains where the equipment should be installed and how to install it. The product incorporates precision parts. Be sure to follow the instructions covered in this document.

### **Chapter 3. Operation Method**

This section illustrates how to change various set values, and describes operation before starting the equipment and after automatic operation. This section also covers the display and action of the equipment during automatic operation.

### **Chapter 4. Maintenance and Servicing**

This section explains the methods for draining water from the exhaust bottle or working chamber, servicing the body, and parts replacement.

### **Chapter 5. Specifications**

This section includes dimensions, power consumption, working range, piping and wiring diagrams of the product. Refer to this section as is required.

### **Chapter 6. In the Event of Suspected Failure**

This section covers troubleshooting procedures for the product. If you encounter anything suspected to be due to failure, read this section first of all.

# Contents

---

Introduction .....	I
Table of Contents .....	I
Before Using .....	II
How to Read This Manual .....	V
Contents .....	VI
Chapter 1. What Is Autoclave HV-25/50/85/110? .....	1
1. Product Uses .....	1
2. Product Features .....	1
3. Name and Functions of Each Part .....	1
Chapter 2. Installation .....	3
1. Installation Instructions .....	3
2. Installation Procedure .....	4
Chapter 3. Operation Method .....	6
Basic Operation Method .....	7
1. Turning "ON" POWER Switch .....	8
2. Pouring Water .....	8
3. Loading Substance .....	9
4. Selecting Mode (Process) .....	10
5. Changing Set Values (Registering Values by Customer) .....	12
6. Checking and Correcting the Clock Time .....	15
7. Checking and Setting of Turn-on Timer .....	17
8. Starting Operation .....	19
9. Unloading .....	21
10. After Completion of Operations .....	21
11. To Interrupt Operation .....	22
12. If Power Supply Is Cut Off during Operation .....	22
13. Operation of Cycles .....	22
Chapter 4. Maintenance and Service .....	26
1. Draining Exhaust Bottle .....	26
2. Draining Working Chamber .....	27
3. Cleaning Working Chamber .....	27
4. Body Service .....	28
5. Replacing Lid Packing .....	28
6. Replacing Backup Battery .....	29
Chapter 5. Specification .....	30
Chapter 6. In the Event of Suspected Failure .....	34
1. Error Detection (Alarming) Operation .....	34
2. Early Trouble Shooting .....	35

# Chapter 1. What Is Autoclave HV-25/50/85/110?

## 1. Product Uses

- This product is designed for research use only (Modes 1 – 3). It is not labeled or marketed for use in medical or clinical applications.
- This product is also used to liquefy media (Mode 4). Mode 4 can also be used to prewarm the chamber for a faster start.

## 2. Product Features

- This product is equipped with a cover for the lid that may be heated at high temperature during use.
- The product incorporates an automatic timer which permits you to begin operation at any desired time within a period of one week.
- The product is provided with a variety of modes of operation. The modes are divided into two broad categories: Sterilization-warming mode and liquefaction mode. If you do not take out the sterilized medium immediately, then select the sterilization-warming mode, and coagulation is prevented. To liquefy a coagulated medium, use the liquefaction mode.
- This autoclave can be set to automatically exhaust % inside the chamber at a desired rate (exhaust valve aperture) after sterilization is over.
- Optional equipment (printer, floating sensor, cooling fan, automatic water supply equipment) can be installed onto the product at a later date.

## 3. Name and Functions of Each Part

### ● Outer View of Body

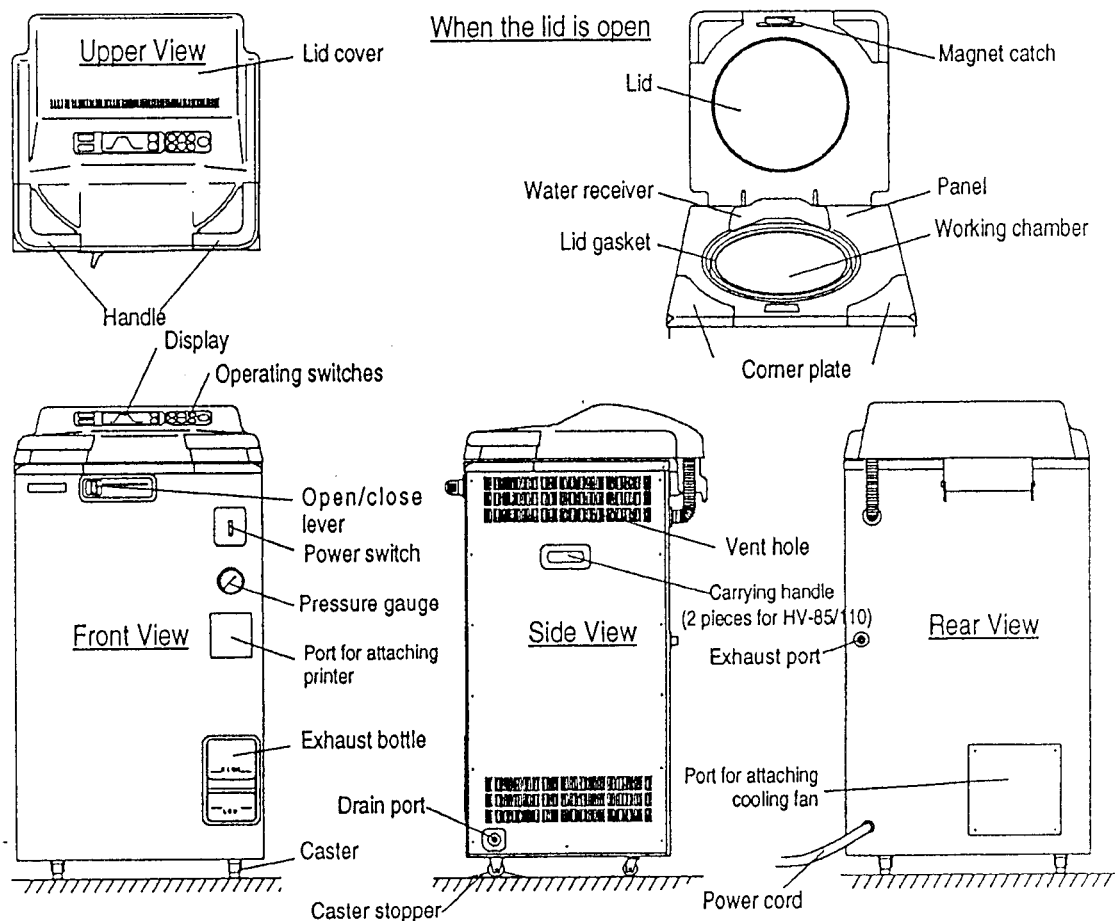



## ●Display and Operation Switches

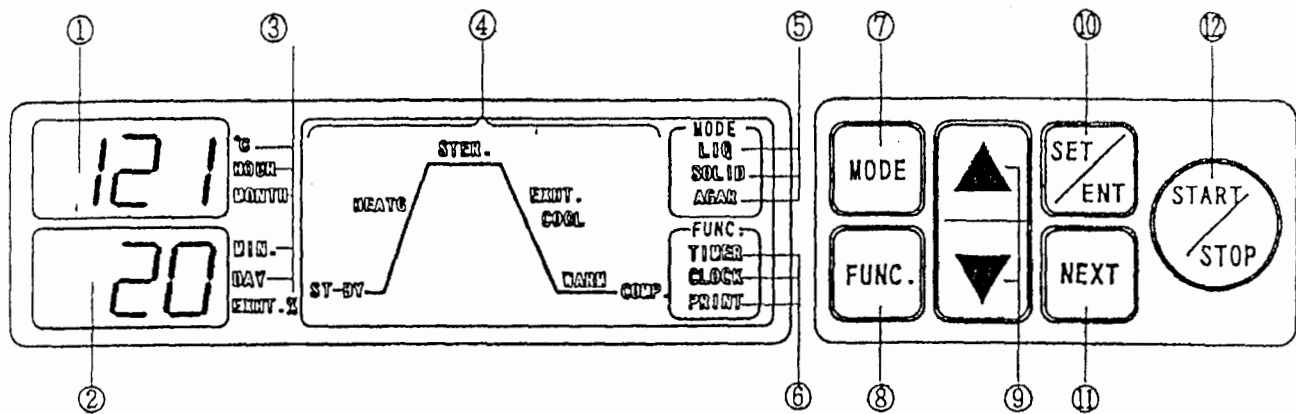

- ① **Digital Display (Temperature, Time of Day, Error)**  
The digital display indicates set temperature, current time and pre-selected time of day when the equipment is in a standby state and it indicates temperature in the working chamber during operation. If any trouble occurs in the equipment and an error is detected, the display indicates the error.
- ② **Digital Display (Time, Time of Day, Exhaust %)**  
The digital display indicates set time, set exhaust %, current time, and pre-selected time of day when the equipment is in a standby state and it indicates remaining time before the completion of sterilization.
- ③ **Unit Display (°C, HOUR, MONTH, MINUTE, DAY, EXHT %)**  
A unit corresponding to a current digital display illuminates.
- ④ **Step Display (ST-BY, HEATG, STER., EXHT., COOL, WARM, COMP.)**  
All the steps included in a selected mode illuminate, and the current step flickers. (COOL display is illuminated when the optional equipment has been installed.)
- ⑤ **MODE Display (LIQ, SOLID, AGAR)**  
The purpose of the selected mode lights up.
- ⑥ **FUNC. Display (TIMER, CLOCK, PRINT)**  
The TIMER display illuminates when you set the turn-on timer or check the contents of its setting, and flickers when you complete setting the timer. The CLOCK display lights up when you check or change the time, and flickers when the backup battery has gone dead. (The PRINT display illuminates when the optional equipment has been installed.)
- ⑦ **MODE Switch**  
This switch is used to select the mode and to check a set temperature or time, or exhaust %.
- ⑧ **FUNC. Switch**  
This switch is used to check the set values for each function.
- ⑨ **SET VALUE INCREASE/DECREASE Switches (▲, ▼)**  
These switches are used to increase or decrease set values.
- ⑩ **SET/ENT Switch**  
This switch is used to change a set value.
- ⑪ **NEXT Switch**  
This switch is used to select the item for which you wish to change the setting.
- ⑫ **START/STOP Switch**  
This switch is used to start or stop operation.

## Chapter 2. Installation

### ⚠ CAUTION

- If the equipment is installed in a place which is 800 m or higher than sea level (i.e. under low pressure in mountain areas), its specifications require to be changed. In this case, be sure to contact us. Do not use the equipment before changing.
- In transporting the equipment, put the lid on and slide the open/close lever to the end of the close side to prevent the lid from opening.
- When moving the lid, do not hold it by the handle, otherwise the lid may become difficult to close.

### 1. Installation Instructions

- ① Avoid installing the equipment in a place where its body may be exposed to water or chemicals, or where corrosive and explosive gases may be produced nearby.

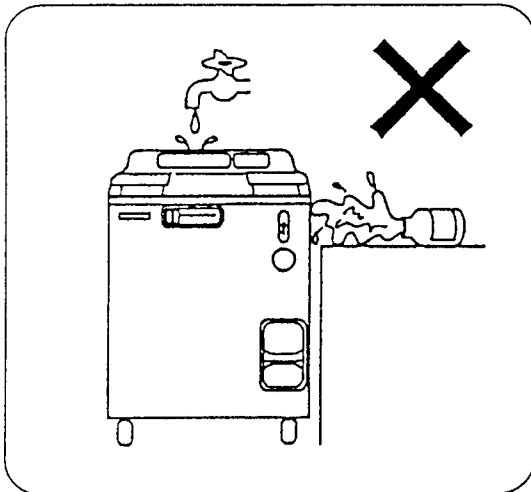

- ② Avoid installing the equipment in a place which is exposed to high humidity, direct sunlight or much dust.

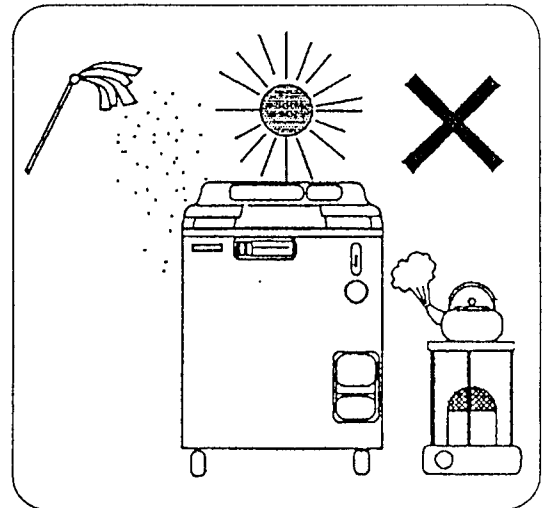

- ③ Avoid placing the equipment directly under a fire detector. If you open the lid immediately after completion of operation, steam comes out of the working chamber, and may activate the detector.

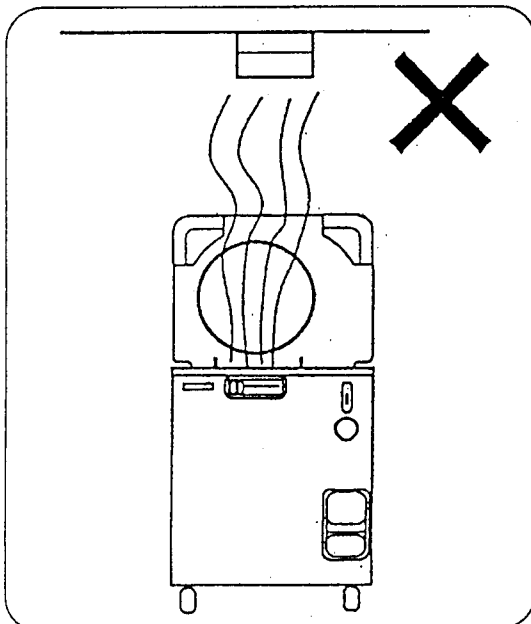

- ④ Arrange the equipment with a clearance of 10 cm or wider on the right side and 12 cm or wider on the rear side to prevent the vent hole from being blocked.

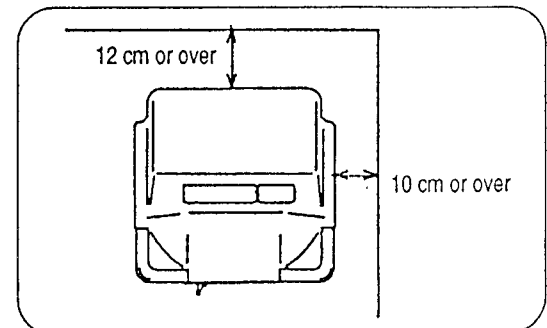

- ⑤ Avoid installing the equipment with its rear side located near outlets or electrical appliances as steam comes out of the exhaust port on the rear.
- ⑥ Avoid an installation place which is subject to impact or vibration.
- ⑦ Place the unit in a level, firm place.
- ⑧ Avoid installing in a place which is subjected to a room temperature of 5°C or below or 35°C or above.

## 2. Installation Procedure

① Put the body on the caster stoppers to prevent the body from accidentally moving.

• Anchor the body as described in the following.

(1) Set the stopper the specified distance from walls.

Specified distance L = HV-25 ..... 49 cm or over

HV-50 ..... 55 cm or over

HV-85/110 ..... 67 cm or over

(2) Push the body until the front casters roll onto the stopper.

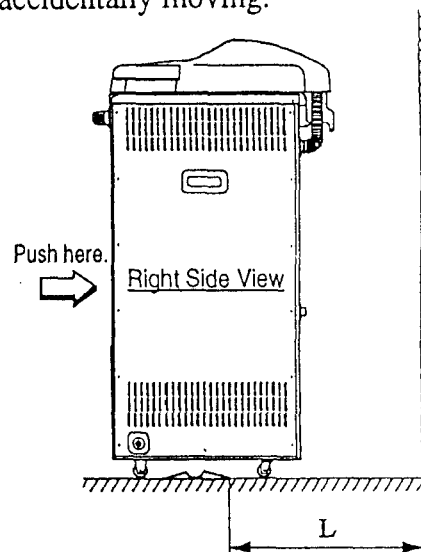

② Connect the power cord to a rated power supply.

• Reliably ground the earth cable.

### WARNING

- Do not forcibly bend, twist, tie or extend the power cord. Do not place heavy objects on the cord. A damaged cord or exposed wire may cause fire or electric shock.
- Never connect the power cord to a power supply other than the voltage that is rated. Connection to such a power supply may cause fire or electric shock.
- If not plugging the sterilizer into a grounded socket, ground the equipment separately before connecting it to a power source.
- Never ground to a gas pipe or vinyl chloride water service pipe.

- Connect the power cord to a grounded electrical outlet.
- Make sure that the outlet voltage corresponds to the voltage of the autoclave (120 VAC or 208/220/240 VAC, 50/60Hz single phase). Check the label on the instrument or the tag on the power cord for the proper voltage requirements.
- If the plug does not fit the outlet, get an electrician to change the outlet receptable or ask him to recommend a suitable plug. The black wire of the power cord is the “hot” wire.

③ Pour water into the exhaust bottle.

- Add water to the exhaust bottle as described below.

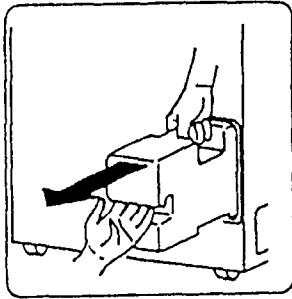

(1) Unload the exhaust bottle from the body.

- Pull the bottle outwards until the top handle can be grabbed securely. Lift the bottle out of the autoclave using this handle.

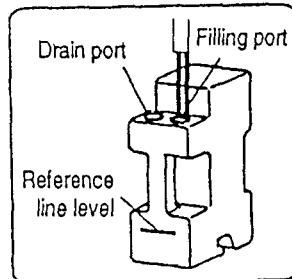

(2) Pour water into the bottle through the water filling port. Fill water to the reference line level.

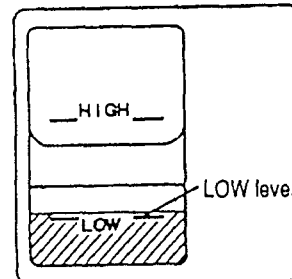

(3) Check to make sure that the water level is at the **LOW** level (the lowest water level).

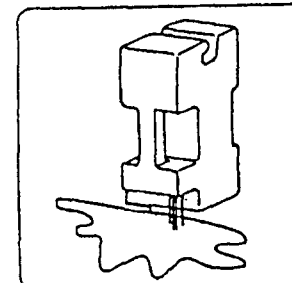

- If too much water has been poured in, then place the bottle in a level sink with the side of the water filling and drain ports facing downwards. Any excessive water is drained automatically until the water level is lowered to the **LOW** level.

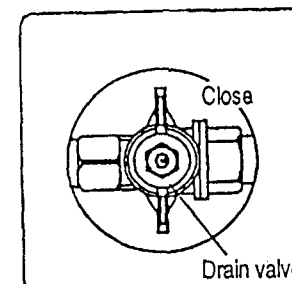

(4) Check to see that the drain valve, located at the bottom of the exhaust bottle housing area, is closed.

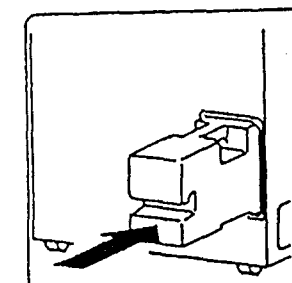

(5) Load the bottle into the area.

- Be sure to push the bottle to the end, or else an error (E r E) will occur.

- ④ Referring to "Chapter 3. Operation Method," open the lid and take out the accessories.
- ⑤ Place the bottom plate in the working chamber.
- ⑥ When the product is operated continuously, steam may be emitted from the exhaust port located at the rear of the body. In this case connect one end of the attached exhaust hose to the exhaust port and place the other end in a container. Discard water collected in the container to prevent the end of the exhaust hose from becoming immersed in water.

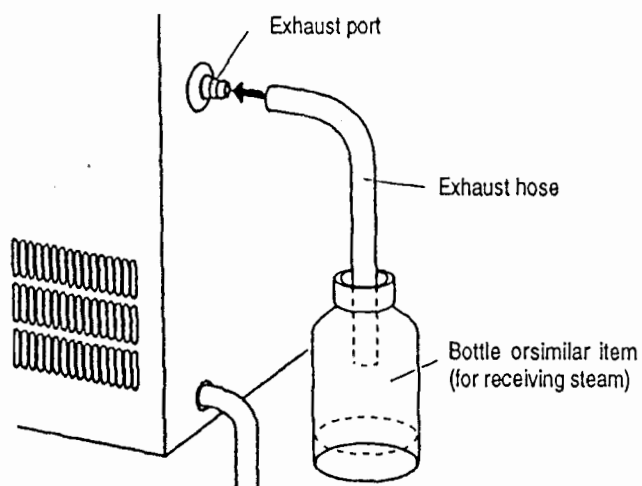

# Chapter 3. Operation Method

## Basic Operation Method

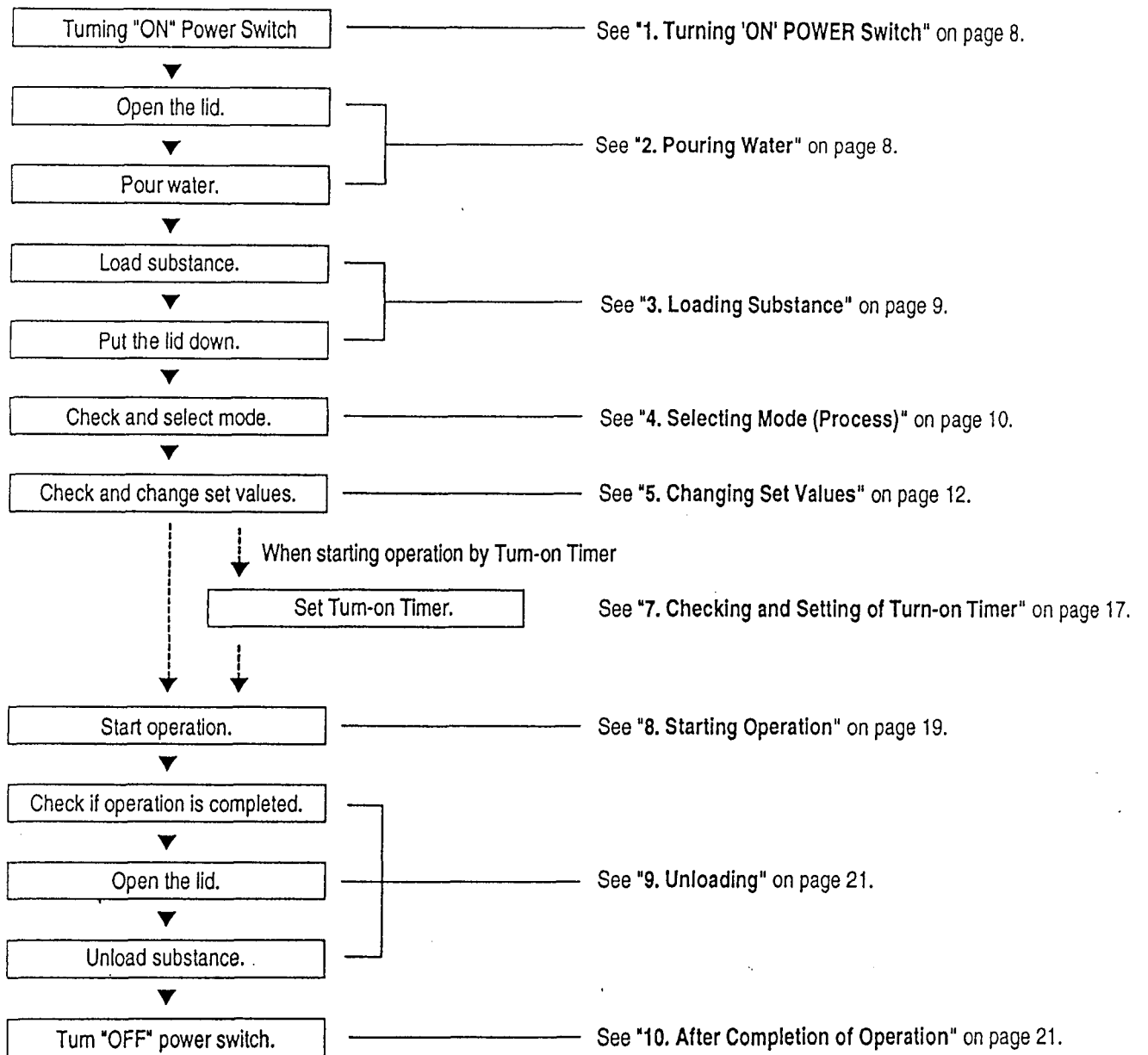

## 1. Turning "ON" POWER Switch

- ① Turn ON the POWER switch at the front of the body.
- When the open/close lever is set to "LOCK" (left side), settings light up on the display. The autoclave is ready in this state. When the open/close lever is set to "UNLOCK" (anywhere other than on the left side), "ST-BY" is shown on the display.

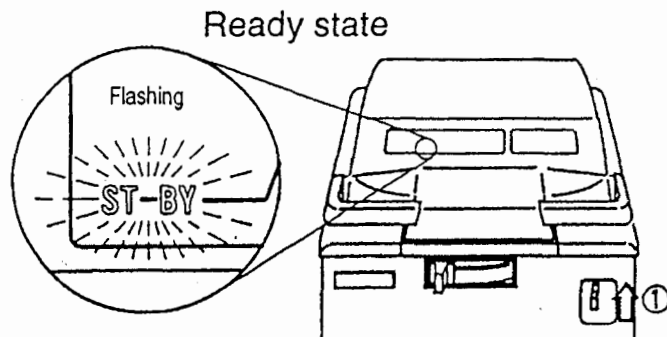

## 2. Pouring Water

### ! IMPORTANT

- In operation of UNLOCK/LOCK lever, never fail to put POWR switch ON.

- ① Slide the open/close lever to the UNLOCK side (the right end).
  - ② Grab the handle, and lift the lid as shown in the figure below.
  - ③ Pour water through the opening of the working chamber until you can see water through the hole at the center of the bottom plate.
- The HV-25 requires 1.5 liters or more of water; the HV-50, 2 liters or more; the HV-85, 4 liters or more; and the HV-110, 5 liters or more. It is also required to pour water for Mode 4 (AGAR).

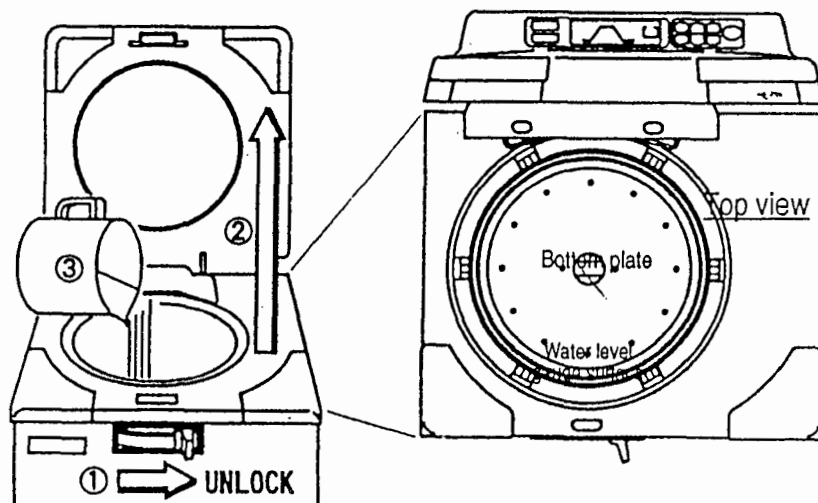

### 3. Loading Substance

#### ⚠ CAUTION

- Be careful not to pinch hands when closing the lid.
- Check to see that the area of the lid that is to come in contact with the lid gasket is free from foreign matter before closing the lid. Foreign matter present in the area may cause the steam leakage.
- Whenever a bag, such as a waste disposal bag, is used for sterilization, put it in the wire mesh basket and place the basket in the working chamber. If the bag is placed directly in the working chamber, the piping may become clogged by it and overheating, overpressurization, and/or lack of water may result.

#### ⚠ IMPORTANT

- Keep the lid open for 15 minutes or more between operations when the equipment is operated continuously. Check to see that the temperature in the working chamber is 50(C or below before starting the next operation (operating the open/close lever).
- Be sure to use the bottom plate.

- ① Place the substance to be sterilized into the working chamber.
- ② Press the lid down until the magnet catch is attracted to the magnet.
- ③ Slide the open/close lever to the LOCK side (the left end).

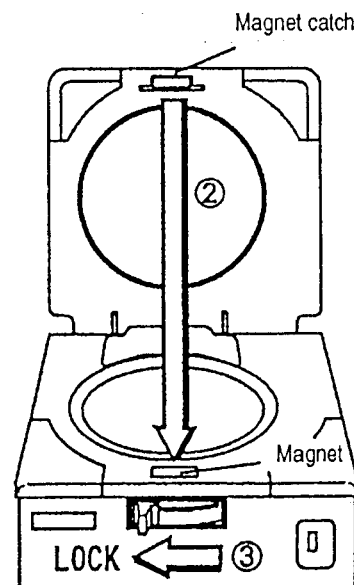

#### △ NOTE

- When sterilizing an empty deep container, lay it on its side in the working chamber so that it will be permeated with steam. An upright position may cause insufficient sterilization.
- If a waste disposal bag is used in sterilization, open the bag far enough that the bag is not in contact with the inside surface of the working chamber. Insufficient sterilization may be caused if the bag is closed during sterilization. When the bag is opened excessively, steam is prevented from circulating in the working chamber. This may also result in insufficient sterilization.



- Do not pile specimens on top of one another. When the chamber is overly packed, steam fails to penetrate to all points, resulting in incomplete sterilization.
- In sterilizing liquids such as chemical and medium, pay attention to the quantity of the liquid in relation to its container. For an Erlenmeyer flask, the amount of chemical should be approx. 3/4 of the capacity of the container; for a test tube, the appropriate quantity of chemical is approx. half of the capacity of the container. Too much chemical may result in overflow from the container during the temperature rising or cooling process.
- When using a container, loosen the cap or use a breathable cap. An unbreathable cap may cause the container to burst.
- In the case of liquefaction of agar medium, its quantity should be 2 liters or less per container. Two liters or more of agar medium may not be completely liquefied.

#### 4. Selecting Mode (Process)

- The following modes are programmed in the microcomputer. Select a mode suitable for your purpose.

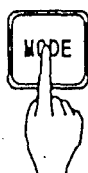

① Press the **MODE** switch.

- Each time you press the switch, the current mode repeatedly changes from Mode 1 to Mode 2, 3, 4, 1, ... in this order.

Mode	Application
1	Sterilization of agar medium (warmed for the prevention of coagulation after sterilization).
2	Sterilization of liquid, such as water, medium, reagent, liquid medicine, that withstand high temperature, high pressure steam.
3	Sterilization of tools of glass, ceramic, metal or rubber that withstand high temperature, high pressure steam and abrupt de pressurization during an exhaust process.
4	Liquefaction of medium.

Mode 1	Step Display	Initial Set Value				Mode Display
		Sterilization Temperature	Sterilization Time	Warming Temperature	Exhaust %	
	HEATG → STER. → EXHT. (Varied) → WARM	121 °C	20 minutes	50 °C	10%	LIQ
			Alternate display			
Mode 2	Step Display	Initial Set Value				Mode Display
		Sterilization Temperature	Sterilization Time	Warming Temperature	Exhaust %	
	HEATG → STER. → EXHT. (Varied)	121 °C	20 minutes		10%	LIQ
			Alternate display			
Mode 3	Step Display	Initial Set Value				Mode Display
		Sterilization Temperature	Sterilization Time	Warming Temperature	Exhaust %	
	HEATG → STER. → EXHT. (Fixed)	121 °C	20 minutes			SOLID
Mode 4	Step Display	Initial Set Value				Mode Display
		Sterilization Temperature	Sterilization Time	Warming Temperature	Exhaust %	
	HEATG → WARM	100 °C	10 minutes	50 °C		AGAR
			Alternate display			

NOTE: Lid can only be opened at approximately 3° below boiling point.

## 5. Changing Set Values (Registering Values by Customer)

- To change set values (sterilization temperature, sterilization time, warming temperature, opening of exhaust valve, liquefaction temperature, liquefaction time), follow the steps below: Settings cannot be changed while the chamber is running except if wanting to change the exhaust rate while exhausting the chamber. For details on changing exhaust rate while exhausting the chamber, see "Exhaust % during the Valve Opening Variable Exhaust Cycle" on page 18.

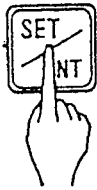

① Press the **SET/ENT** switch.

- The display of a set sterilization (liquefaction) temperature starts flickering. This indicates that the set value is now changeable.

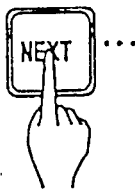

② Press the **NEXT** switch to select an item the setting of which you desire to change.

- Each time you press the switches, the changeable set items change repeatedly as follows:

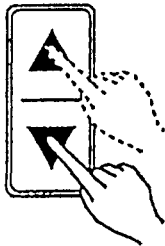
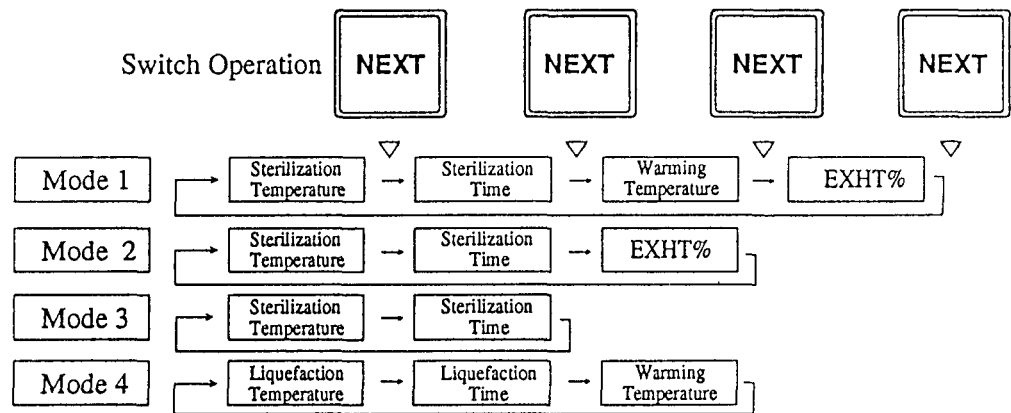

③ Change the displayed value using the setting increase/decrease switches (▲, ▼).

- Each time you press the switches, the displayed value increases or decreases as follows:

Sterilization temperature:

In increments of 1°C within a range of:

**HV-25** 105 - 126°C

**HV-50** 105 - 135°C

**HV-85** 105 - 135°C (105 - 128°C)\*

**HV-110** 105 - 135°C (105 - 123°C)\*

\* Specification for particular area



Sterilization time: 1 minute increments within a range of 1-250 minute  
 Liquefaction temperature: In increments of 1°C within a range of 60-100°C

Liquefaction time: 1 minute increments within a range of 1-60 minutes

Warming temperature: 1°C increments within a range of 45-60°C

EXHT %: 1% increments within a range of 0-100%

- If you hold the switch down, the displayed value increases or decreases in 10 unit increments. When the displayed value exceeds the upper limit (lower limit), it returns to the lower limit (upper limit).

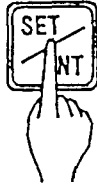

④ Press the **SET/ENT** switch.

- The changed value is stored, the display stops flickering and lights up. This completes the setting.

#### Canceling Changing the Set Values

- If halfway you desire to cancel the setting change, press the **MODE** switch. The changed value is not stored, and the equipment returns to a standby state.

#### △ NOTE

- For sterilization of liquid, set a sterilization time longer than desired, taking delay time into account and referring to the table below.

Example) In case there is 3 liters of water in a flask, it takes nearly 30 minutes (delay time) for temperature of water in the container to reach a set sterilization temperature after temperature in the working chamber reaches the set value. You should set a sterilization time 30 minutes longer than desired to cope with this delay of time. Therefore, the set sterilization is 50 minutes:

Set sterilization time (50 minutes)

= Delay time (30 minutes) + desired sterilization time (20 minutes)

HV-50 Reference Values of Delay Time (per Flask)

Quantity of Liquid	Delay Time
3 liters	30 minutes
2 liters	25 minutes
1 liter	20 minutes
500 cc	15 minutes

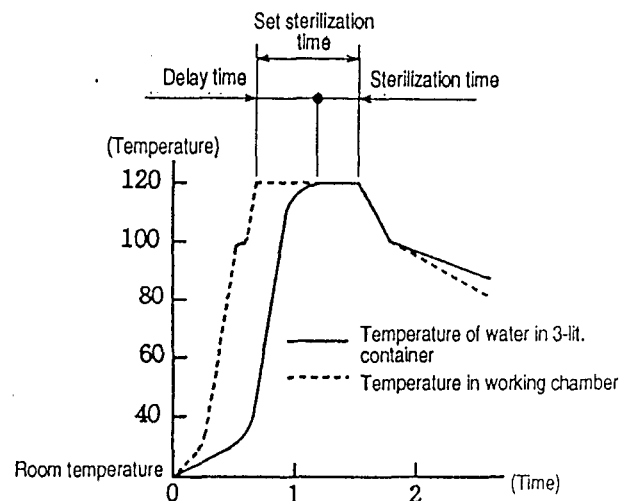

HV-50 Delay Time Reference Data

- If steam is abruptly exhausted after sterilization of liquid, the liquid may gush out. To prevent this, set the opening of the exhaust valve (Exhaust %) to a small value to gradually exhaust. Or, set that to 0% (spontaneous cooling).

- When used with a sterilization can, it takes several hours for the temperature in waste disposal bag to reach the set temperature after the temperature in the working chamber (displayed temperature) reaches the set value (time lag).

If there is approx. 300 - 500 milliliters of water in the waste disposal bag, steam is generated in the bag and drives the air out. This will significantly reduce the time lag at the time of temperature rise. Refer to the table below and take this time lag into account when setting the fertilization time.

Model: HV-110

Case: A large number of Ø15 x 100 test tubes placed in a waste disposal bag

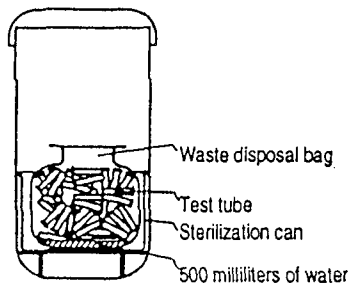

**HV-110 Reference Values for Time Lag in Bag**

Water in Bag	Time Lag
Absent	206 minutes
Present	48 minutes

- For liquefaction of coagulated agar medium, set an appropriate liquefaction temperature and time, referring to the table below.

**HV-50 Reference Values (per Flask)**

Quantity of Liquid	Liquefaction Temperature	Liquefaction Time
2 liters	100 °C	60 minutes
1 liter		45 minutes
500 cc		25 minutes

- Mode, temperature, time and opening of exhaust valve remain in the memory by means of the backup battery even after the power switch is turned off. When the backup battery has run down, the CLOCK display flickers, and the initial set values for Mode 1, described in the previous section, come back on display. In this case, call the authorized sales outlet from which you purchased the product.

## 6. Checking and Correcting the Clock Time

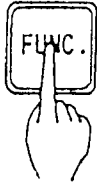

- ① With the equipment in a standby state, press the **FUNC.** switch twice.
- The **CLOCK** display lights up, and the current time appears on the digital displays.

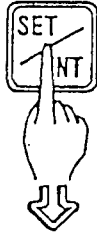

- ② Check to see that the displayed time is correct.
- If the time is correct: Press the **MODE** switch. (Returns to a standby state)
  - If the time is incorrect: Go to ③.

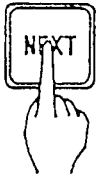

- ③ Press the **SET/ENT** switch.
- The **MONTH** display starts flickering. This indicates that the clock is now ready for correction.
- ④ Press the **NEXT** switch to select the item the setting of which you wish to change.
- Each time you press the switches, the changeable set items change repeatedly as follows:

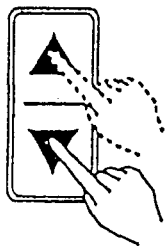
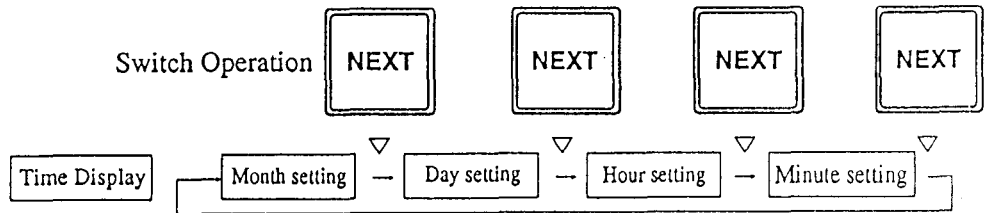

- ⑤ Change the displayed value using the **setting increase/decrease** switches (▲, ▼).
- Each time you press the switches, the displayed value increases or decreases as follows:
    - Month setting: 1 month increments within a range of 1-12
    - Day setting: 1 day increments within a range of 1-31
    - Hour setting: 1 hour increments within a range of 0-23
    - Minutes setting: 1 minute increments within a range of 0-59
  - If you hold the switches down, the displayed value increases or decreases in increments of 10 units. When the displayed value exceeds the upper limit (lower limit), it returns to the lower limit (upper limit).



⑥ Press the **SET/ENT** switch.

The corrected current time is stored, and the equipment returns to a standby state.

#### Canceling Correcting Clock

- If halfway you desire to cancel correction of the clock, press the **MODE** switch. The changed current time is not stored, and the equipment returns to a standby state.

#### △ NOTE

- The clock continues working by means of a backup battery even after the power switch is turned off. When the backup battery has run down, the **CLOCK** display flickers. In this case, call us or our authorized sales outlet from which you purchased the product.

## 7. Checking and Setting of Turn-on Timer

### ! IMPORTANT

- Invalid setting of the turn-on timer and an incorrect clock may lead to equipment malfunctions. Be sure to check the clock and correct it if necessary before setting the turn-on timer.

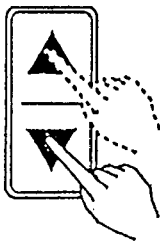
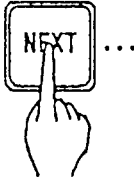
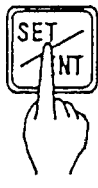

- ① With the equipment in a standby state, press the **FUNC.** switch once.
  - The **TIMER** display lights up, and the default value of the turn-on timer (the initial set value of operation start time) will appear on the digital display.

- ② Press the **SET/ENT** switch, and the day(s)-later display starts flickering. This indicates that it is now ready to be changed.

- ③ Press the **NEXT** switch to select the item you wish to change the setting of.
  - Each time you press the switches, the changeable set items change repeatedly as follows:

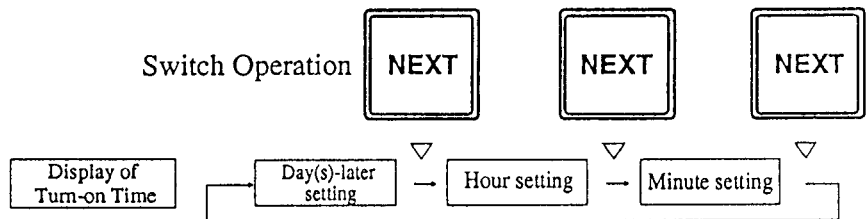

- ④ Change the displayed value using the **setting increase/decrease** switches (▲, ▼).

- Each time you press the switches, the displayed value increases or decreases as follows:

Day(s)-later setting: 1 day increments within a range of 0 - 6

Hour setting: 1 hour increments within a range of 0 - 23

Minute setting: 1 minute increments within a range of 0 - 59

- If you hold down the switches, the displayed value increases or decreases in 10 unit increments. When the displayed value exceeds the upper limit (or lower limit), it returns to the lower limit (or upper limit).



### Example of Setting:

When you desire to start operation at 11:30 p.m. today, your setting should be as follows: Day(s)-later setting = 0, Hour setting = 23, Minute setting = 30

When you desire to start operation at 5:00 a.m. the day after tomorrow, your setting should be as follows: Day(s)-later setting = 2, Hour setting = 5, Minute setting = 0

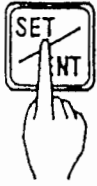

⑤ Press the **SET/ENT** switch.

- The set turn-on time is stored, and the equipment returns to the standby state with the **TIMER** display on. (If you enter a time before the current time, an electronic alarm sounds and display of the day(s)-later setting starts flickering. In this case, check the turn-on time you set, and correctly set the turn-on timer again.

#### Canceling Setting Turn-on Timer

- If halfway you desire to cancel setting the turn-on timer, press the **MODE** switch. The changed turn-on time will not be stored, and the equipment returns to the standby state.

#### △ NOTE

- Operation will not start at the set time unless the **START/STOP** switch has been pressed, even after completion of setting the turn-on timer.
- To cancel a time set on the turn-on timer, turn off the power switch, and the set turn-on time will be ignored.
- A turn-on timer setting is effective for only one operation.
- If operation is stopped before the reaching the set start time, the start time setting is kept unchanged.

## 8. Starting Operation

① Check again to see that the water level in the exhaust bottle is between the **HIGH** and **LOW** levels.

••If above the **HIGH** level ... See "2. Draining Working Chamber" on page 27.

••If below the **LOW** setting ... See "2. Installation Procedure ③" on page 5.

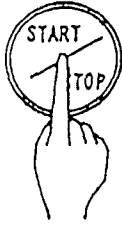

② Press the **START/STOP** switch.

• The open/close lever is locked, and it is become impossible to open the lid. Thereafter, one of the following processes is performed depending on the chosen mode of operation. For details on each specific mode, see "13. Operation of Cycles" on pages 22 to 25.

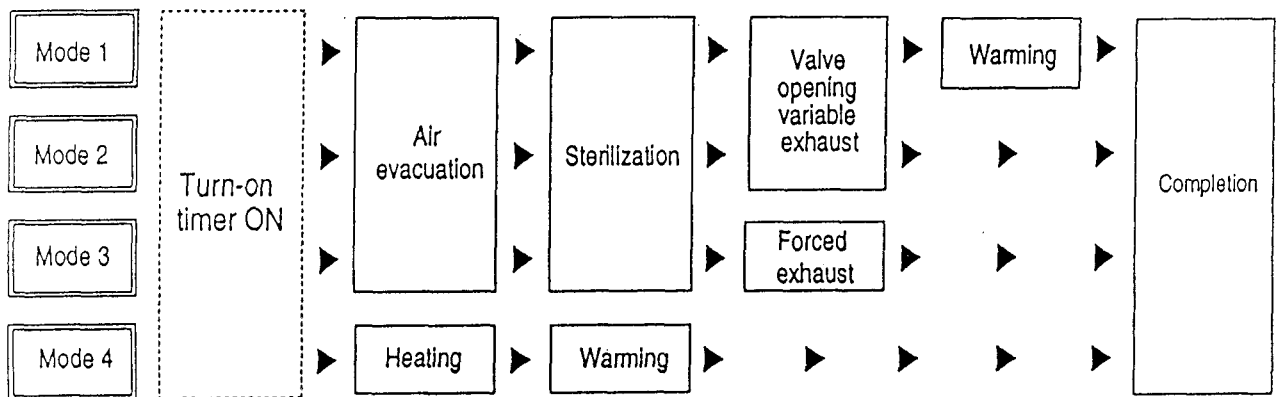

### Checking Turn-on Time Setting During Turn-on Timer on Cycle

- To check the turn-on time set on the timer during the turn-on timer on cycle, press the **FUNC.** switch. While you are holding down the switch, the set time remains on the display. A set turn-on time is unchangeable.
- After the turn-on timer on cycle, the display of the turn-on time setting will read "0 day(s) later, 0 hour, 00 min."

### Checking Set Values During Operation

- To check the set values for temperature, time or opening of the exhaust valve during operation, press the **MODE** switch. While you are holding down the switch, the set value remains on display. Set values are not changeable.

## Exhaust % During the Valve Opening Variable Exhaust Cycle

- ① Press the **SET/ENT** switch.
  - The display of opening of the exhaust % display starts flickering, and indicates that it is now ready to be changed.
- ② Change the numeric value using the set value **increase/decrease** switches (**▲**, **▼**).
  - Each time you press the switches, the displayed value increases or decreases in 1% increments within a range of 1-100%.
  - If you hold down the switches, the displayed value increases or decreases in 10% increments. When the displayed value exceeds the upper limit (or lower limit), it returns to the lower limit (or upper limit).
- ③ Press the **SET/ENT** switch.
  - The changed value will be stored, and the display stops flickering and lights up again. The exhaust valve is controlled according to the set exhaust %. (The stored numerical value is also effective for the next operation.)

## 9. Unloading

### WARNING

- Check to see that the gauge for pressure in the working chamber reads 0 kgf/cm<sup>2</sup>.

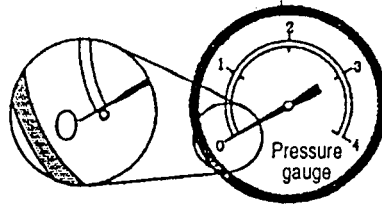

### CAUTION

- Do not put your face or hands close to the working chamber when lifting the lid after operations are complete; steam will gush out of the opening of the chamber.
- After operation is over, the lid, chamber, packing and panel are hot. To protect yourself from burns, do not touch with bare hands.
- It takes a lot of time for the liquid to cool. Be sure to check that the temperature has dropped sufficiently before unloading the liquid from the working chamber, or you may get burned.
- Put on heat insulation gloves before taking a substance out of the working chamber. Do not put your hands into the chamber until the steam has been vented.

- ① Slide the open/close lever to the UNLOCK side (to the right).
- ② Lift the lid.
- ③ Take the sterilized substance out of the working chamber.

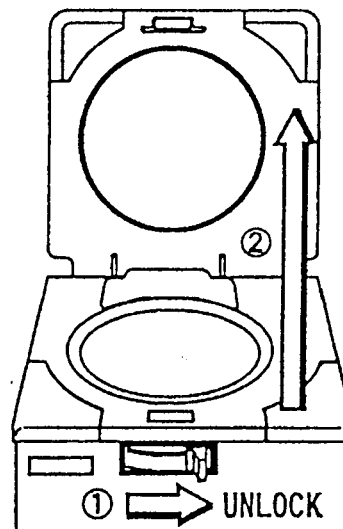

## 10. After Completion of Operations

- ① Turn off the power switch after the completion of each routine operation.

### IMPORTANT

- To prevent clogging of the piping, change water within the working chamber once daily, referring to "Draining Working Chamber" on page 27.

## 11. To Interrupt Operation

### △ NOTE

- If operation is interrupted during the sterilization of liquid, the liquid may overflow into the working chamber.

① Press the **START/STOP** switch.



- The ongoing process will be interrupted, and the equipment returns to the standby state (state before operation).
- When you take the sterilized substance out of the working chamber, follow the instructions described in "9. Unloading". (When chamber temperature drops below 97°C (or 79°C)\* in the SOLID mode, pressure drops to 0 kgf/cm<sup>2</sup>. In this state, the open/close lever can be unlocked.)  
(If a floating sensor is used, the sensor regulates the open/close lever by sensing the temperature.)

\* In LIQ mode available in specifications for particular area.

## 12. If Power Supply Is Cut Off during Operation

- If the power supply is cut off due to power failure or the like, operation is interrupted. When power supply is restored, the equipment will be back in the standby state (state before operation). In this case, repeat operations from the beginning.

### △ NOTE

- If power supply is cut off due to power failure or the like, the open/close lever is locked for safety. To open or close the lid, follow the instructions described in "9. Unloading" on page 21 after the power supply has been restored.

## 13. Operation of Cycles

■ Turn-on Timer On Cycle --- Common to all the modes  
(with the turn-on timer set)

- The digital display section illuminate in a circular manner until the time set on the turn-on timer (preset time of operation start-up) is reached.
- When the time set on the turn-on timer is reached, the **TIMER** digital goes off, and operation proceeds to the next cycle.

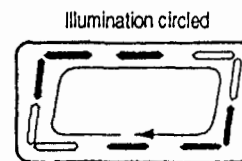

■ Air Evacuation Cycle --- Mode 1, 2 and 3

- The **ST-BY** display stops flickering and lights up; then the **HEATG** goes off and start flickering. The temperature in the working chamber is displayed in the digital temperature display section.

- Any air remaining in the working chamber makes the temperature distribution in the chamber uneven. This hinders temperature rise (sterilization). To cope with this, a microcomputer-controlled automatic exhaust valve vents virtually 100% of the air.
- Temperature rises until a set sterilization temperature (pressure) is reached.
- After the set sterilization temperature is attained, the HEATG stops flickering and lights up. Operation proceeds to the next step.

#### ■ Sterilization Cycle --- Modes 1, 2 and 3

- The STER. display goes out and starts flickering. The set sterilization time is shown in the digital display upon activation of the sterilization timer.
- A constant temperature (pressure) is maintained during the set sterilization time period.
- If the temperature in the working chamber drops 1°C or more from the set value due to any trouble, the temperature over-drop mark appears on the digital display, and the digital timer operation is interrupted. When the set temperature is regained, the timer restarts operation.
- The digital timer displays the remaining time during the sterilization cycle. Refer to "**Checking Set Values during Operation**" on page 19 for the method of checking the set time during operation.
- When the preset sterilization time has passed, the STER. display stops flickering and lights up, and operation proceeds to the next cycle.

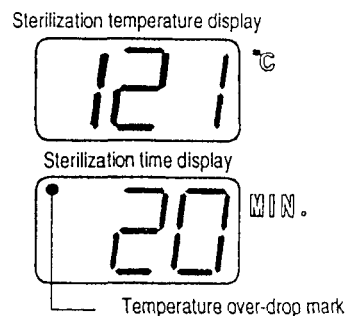

#### △ NOTE

- In sterilization of petri dishes or empty containers, the air remaining in the container expands and may increase the pressure extraordinarily within the working chamber. If the pressure in the working chamber exceeds the saturated steam pressure, the automatic exhaust valve opens and discharges the air in the chamber into the exhaust bottle.

#### ■ Valve Opening Variable Cycle --- Modes 1 and 2

- The EXHT. display goes out and starts flickering. The digital display indicates the exhaust % value.
- You can change the exhaust % value during the valve opening variable exhaust cycle. To do so, refer to "**Exhaust % During the Valve Opening Variable Exhaust Cycle**" on page 20.

#### △ NOTE

- If the steam is exhausted abruptly after liquid sterilization, the liquid may gush out. To prevent this, set the exhaust % to a small value to gradually exhaust the steam. Or, set that to 0% (spontaneous cooling).

- When the pressure in the working chamber falls below 0.1 kgf/cm<sup>2</sup>, the exhaust valve is fully opened.
- When the temperature in the working chamber (or the temperature registered by the floating sensor, if used) falls to 97°C (or 79°C)\*, the EXHT. display stops flickering and lights up. The display of opening of the exhaust valve (exhaust %) disappears from the digital display, and operation proceeds to the next cycle.

\* Specifications for particular area.

#### ■ Forced Exhaust Cycle --- Mode 3

- The EXHT. display goes out and starts flickering, and the automatic exhaust valve is fully opened.
- When the temperature in the working chamber falls to 97°C, the EXHT. display stops flickering and lights up, and operation proceeds to the next cycle.

#### ■ Heating Cycle --- Mode 4

- The ST-BY display stops flickering and lights up, and the HEATG display goes out and starts flickering. The digital display indicates the temperature in the working chamber.
- Temperature rises until a set liquefaction temperature is reached.
- After the set temperature is reached, a set liquefaction time is shown on the digital display upon the activation of the liquefaction timer.
- The digital timer displays the remaining time during the heating cycle. Refer to "Checking Set Values during Operation" on page 19 for the method of checking the set time during operation.
- When the time preset for liquefaction has passed, the HEATING LED stops flickering and lights up, and operation proceeds to the next cycle.

#### ■ Warming Cycle --- Modes 1 and 4

- The WARM display goes out and starts flickering.
- When the temperature in the working chamber falls to a set incubation temperature, the electronic alarm gives a beeping sound.
- When 20 hr. (fixed) have passed after the temperature drops to the set incubation temperature, the WARM display stops flickering and lights up, and operation proceeds to the next cycle.

#### △ NOTE

- After the warming time (20 hr.) has passed, the working chamber is not heated; temperature in the chamber falls to room temperature, and the remaining agar medium, if any, in the chamber will be coagulated.
- When you take a sterilized substance out of the working chamber during the warming cycle, press the START/STOP switch to stop operation. Refer to "9. Unloading" on page 21.

■ Completion Cycle --- Common to all the Modes

- When all cycles of each mode are complete, the electronic alarm indicates completion of all cycles by giving a beeping sound three times. Then the COMP. display goes out and starts flickering.

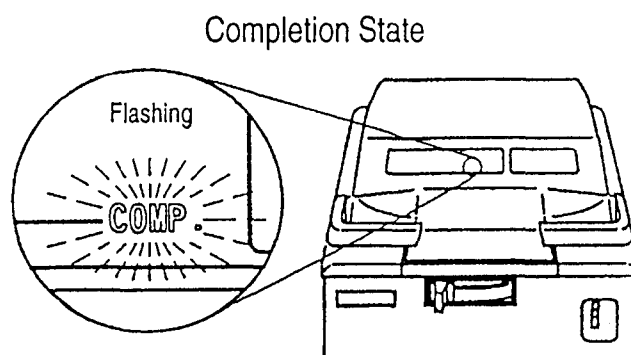



 **CAUTION**

- Be sure to start maintenance or service work after the main body has been sufficiently cooled.

### 1. Draining Exhaust Bottle

- Water collects in the exhaust bottle as operations are repeated. If the water level is above the **HIGH** level (allowable highest water level), drain the bottle in accordance with the following procedures.

 **CAUTION**

- Do not unload the exhaust bottle before water in the bottle has been sufficiently cooled.

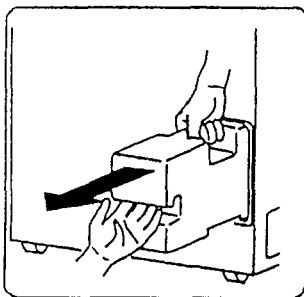

- ① Remove the exhaust bottle from the body.
  - Pull the bottle outwards until the top handle can be grabbed securely.

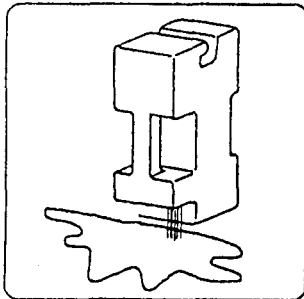

- ② Place the bottle in a level sink with the water filling and drain ports facing downwards.
  - Excessive water is drained automatically until the water level is lowered to the **LOW** level (lowest allowable water level).

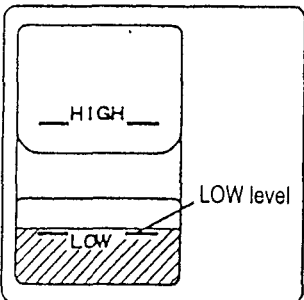

- ③ Be sure that the water level is at **LOW** level.
  - Ensure that water is left at the **LOW** level (lowest allowable level), which is required for sufficiently cooling the steam.

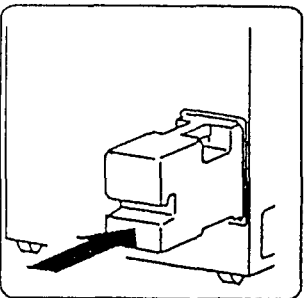

- ④ Loading the exhaust bottle into the bottle housing area.
  - Be sure to push the bottle to the end, or else an error (E<sub>r</sub>-E) will occur.

## 2. Draining Working Chamber

- When you plan to put the equipment out of service for a long time, be sure to drain the working chamber to prevent the clogging of pipes. After checking that the working chamber has been sufficiently cooled, drain the chamber in accordance with the following procedure.

### CAUTION

- Do not unload the exhaust bottle or drain the working chamber when the chamber is under pressure. Boiling water or steam may gush out, and you may get burned.

- ① Open the lid.
- ② Connect one end of the attached drain hose to the tap of the drain valve located at the lower part of the right side of the body.
- ③ Put the other end of the hose in a container.
- ④ Remove the exhaust bottle from the body.
- ⑤ Turn the drain valve knob, which is located at the bottom of the exhaust bottle housing area, counterclockwise to open it.
- ⑥ Check if draining working chamber is complete.
- ⑦ Turn the knob clockwise to close the drain valve.
  - Close the valve with reliability.

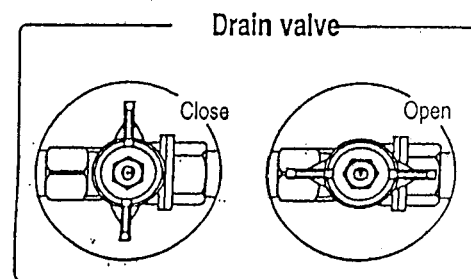
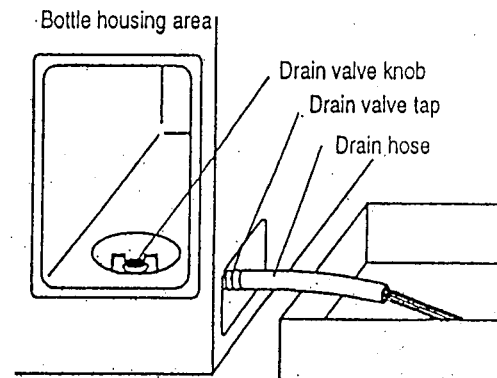

## 3. Cleaning Working Chamber

### CAUTION

- The heater is provided with a temperature sensor, be careful not to damage it while cleaning.

- ① Take out the bottom plate to see if the bottom of the working chamber or the surface of the heater is dirty. After draining the chamber, clean them with a soft brush or the like while sprinkling water with the drain valve open.
- ② If the temperature sensor clip comes loose, reattach it as close to the heater as possible.
  - Please contact us or our authorized sales outlet for the chamber cleaning detergent "Lister".

### Inside the Chamber

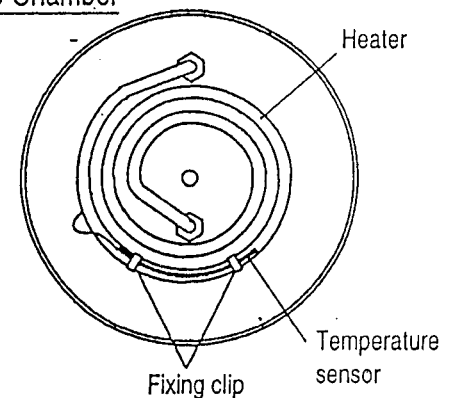

#### 4. Body Service

### ! IMPORTANT

- Do not use benzine or thinner to clean the body. Also make sure that the volatile substances such as insecticides do not come into contact with the body as these substances may deteriorate the body or strip its paint.

- ① Gently wipe stains from the body with a soft cloth. To remove stubborn stains, wring a cloth moistened with neutral detergent diluted with water, and wipe off the stains with it. Wipe off any moisture with a dry cloth.

#### 5. Replacing Lid Gasket

- Lid gasket with a whitened edge may cause steam leakage. Replace the lid gasket, if whitened, in accordance with the following procedure:

- ① Open the lid.
- ② Apply the minus screwdriver to the underside of the gasket band, and pry it up. Pull out the old gasket.
- ③ Using a waste cloth wipe any dirt off the portion of the working chamber with which the gasket was in contact.
- ④ Remove the gasket band from the old gasket, and using a waste cloth wipe any dirt off the gasket band.

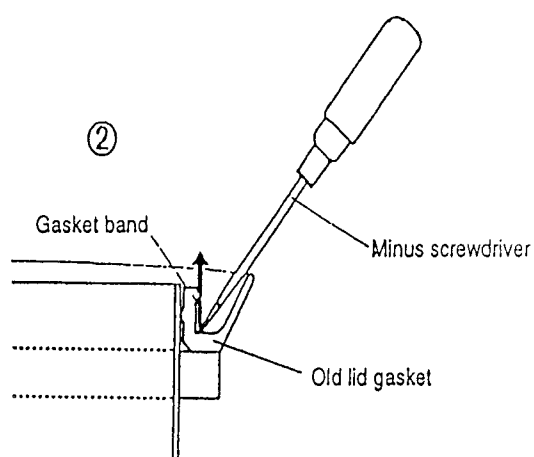

- ⑤ Attach the gasket band to the new gasket:
  - (1) Place the new gasket on a flat surface, and push in the gasket band until it hits against the bottom of the groove.
  - (2) Insert the cord which prevents the gasketband from coming off.

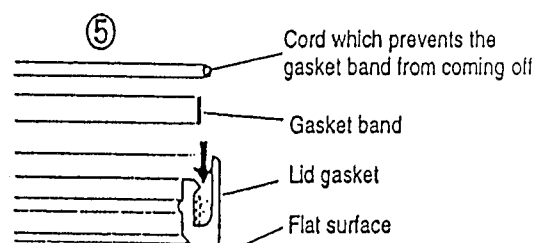

- ⑥ Install the new gasket in the working chamber:

- (1) Push in the gasket until the entire projected portion of the gasket hits against the rim of the working chamber. Gradually and evenly insert the entire gasket while pressing your palm on the gasket.

- If the gasket band starts to come off, press the wooden stick against it to shove the band into the groove in the gasket while taking care not to damage to the gasket.

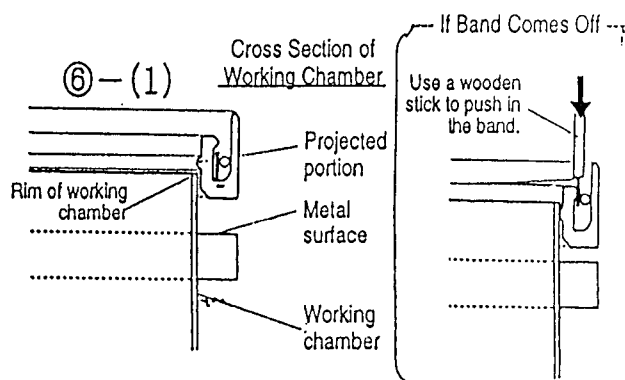

(2) Push in the gasket unit it hits against the metal surface. When the gasket is completely pushed in, the flat portion is positioned at a level slightly lower than the rim of the working chamber.

(3) In addition, run your finger down the flat portion of the gasket to eliminate any irregularities on the gasket surface.

- An uneven gasket surface makes the lid difficult to close.

(7) Pull out the cord which prevents the gasket band from coming off.

(8) Follow the ordinary operating procedure to start operation and check the lid gasket for any leakage.

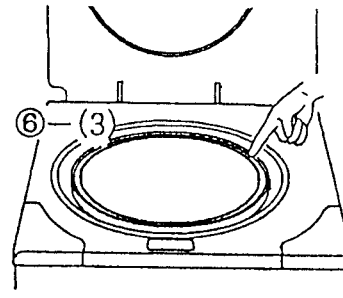
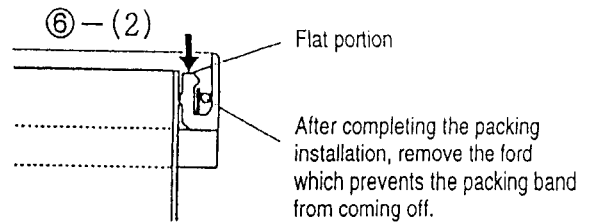

## 6. Replacing Backup Battery

- When the **CLOCK** display flickers, Replace the backup battery in accordance with the following procedure.

### **WARNING**

- Do not dispose of used batteries in fire; they may explode.
- Connecting the battery with its polarities reversed may cause heating, explosion or ignition.

- ① Turn **OFF** the power switch.
- ② Remove the panel from the right side of the body.
- ③ Hold both the ends of the connector for the backup battery between your fingers, and pull the connector out of the switch board.
- ④ Remove the screw from the clamp.
- ⑤ Attach the clamp to a new battery, and tighten the screw to secure the clamp on the switch board.
- ⑥ Insert the connector for the battery into the printed circuit board, being careful not to make a mistake in its positioning.
- ⑦ Attach the side panel to the body.
- ⑧ Turn **ON** the power switch, and correct the clock.
  - When the correction of the clock is complete, the **CLOCK** display goes out.
- ⑨ In the case a setting other than the values initially set is used, set the values again.

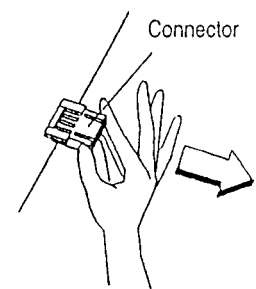
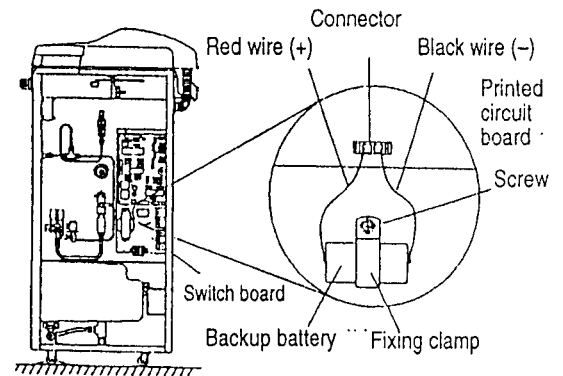

## Chapter 5. Specification

Model	HV-25	HV-50
Outside dimensions	480W × 950H × 460D mm	540W × 1040H × 530D mm
Inside dimensions	240 mm dia. × 550 mm depth (Effective: 25 liters)	300 mm dia. × 710 mm depth (Effective: 50 liters)
Rated power supply	AC V ±10% Single-phase 50/60Hz (More than A)	AC V ±10% Single-phase 50/60 Hz (More than A)
Temperature and humidity conditions	5~35°C, 10~85%RH (No condensing)	
Power consumption	1.5KW ( A)	2.0KW ( A)
Weight	41kg	57kg
Type of pressure vessel	Simplified pressure vessel	Compact pressure vessel
Material of working chamber body	SUS304 (stainless steel)	
Setting range of sterilization temperature	105~126°C variable	105~135°C variable
Sterilization timer	1~250 minutes·Remaining time displayed.	
Setting range of liquefaction temperature	60~100°C variable	
Liquefaction timer	1~60 minutes·Remaining time displayed	
Setting range of warming temperature	45~60°C variable	
Range of opening of exhaust valve	0~100% variable	
Turn-on timer	1 min. - 1 week later·Start-up time to be set.	
Maximum operating pressure	1.9 kgf/cm <sup>2</sup> (0.186MPa)	2.6 kgf/cm <sup>2</sup> (0.255MPa)
Thermometer	Digital display 5~128°C	Digital display 5~137°C
Clock	24-hour system. Date and time of day alternately displayed.	
Pressure gauge	Analog display 0~4 kgf/cm <sup>2</sup> (0~0.4MPa)	
Backup battery life	Approx. 5 years	
Safety alarm device	Pressure safety valve, electric leakage breaker, lack-of-water prevention device, error display (lack-of-water, temperature sensor wire breakage, over-temperature, over cooling, over pressure, open/close lever locking failure)	
Accessories	Exhaust bottle (1 pc) Bottom plate (1 pc) Exhaust hose 20 cm (1 pc) Exhaust hose 40 cm (1 pc) Guarantee card (1 sheet) Operation manual (1 copy) Caster stopper (2 pcs)	Exhaust bottle (1 pc) Bottom plate (1 pc) Exhaust hose 20 cm (1 pc) Exhaust hose 40 cm (1 pc) Drain hose (1 pc) Guarantee card (1 sheet) Operation manual (1 copy) Caster stopper (2 pcs)

Model	HV-85	HV-110
Outside dimensions	660W × 1000H × 650D mm	660W × 1180H × 650D mm
Inside dimensions	420 mm dia. × 615 mm depth (Effective: 85 liters)	420 mm dia. × 795 mm depth (Effective: 110 liters)
Rated power supply	AC V ±10% Single-phase 50/60Hz (more than A)	AC V ±10% Single-phase 50/60 Hz (more than A)
Temperature and humidity conditions	5~35°C, 10~85%RH (No condensing)	
Power consumption	3.0KW ( A)	4.0KW ( A)
Weight	71kg	81kg
Type of pressure vessel	Compact pressure vessel	
Material of working chamber body	SUS304 (stainless steel)	
Setting range of sterilization temperature	105~135°C variable (105~128°C variable)*	105~135°C variable (105~123°C variable)*
Sterilization timer	1~250 minutes·Remaining time displayed.	
Setting range of liquefaction temperature	60~100°C variable	
Liquefaction timer	1~60 minutes·Remaining time displayed	
Setting range of warming temperature	45~60°C variable	
Range of opening of exhaust valve	0~100% variable	
Turn-on timer	1 min. ~ 1 week later·Start-up time to be set.	
Maximum operating pressure	2.6 kgf/cm <sup>2</sup> (0.255MPa) (2.0 kgf/cm <sup>2</sup> (0.196MPa))*	2.6 kgf/cm <sup>2</sup> (0.255MPa) (1.6 kgf/cm <sup>2</sup> (0.157MPa))*
Thermometer	Digital display 5~137°C (Digital display 5~130°C)*	Digital display 5~137°C (Digital display 5~125°C)*
Clock	24-hour system. Date and time of day alternately displayed.	
Pressure gauge	Analog display 0~4 kgf/cm <sup>2</sup> (0~0.4MPa)	
Backup battery life	Approx. 5 years	
Safety alarm device	Pressure safety valve, electric leakage breaker, lack-of-water prevention device, error display (lack-of-water, temperature sensor wire breakage, over-temperature, over cooling, over pressure, open/close lever locking failure)	
Accessories	Exhaust bottle (1 pc) Bottom plate (1 pc) Exhaust hose 20 cm (1 pc) Exhaust hose 40 cm (1 pc) Guarantee card (1 sheet) Operation manual (1 copy) Caster stopper (2 pcs)	

\* Specification for particular area.

# Piping Diagram

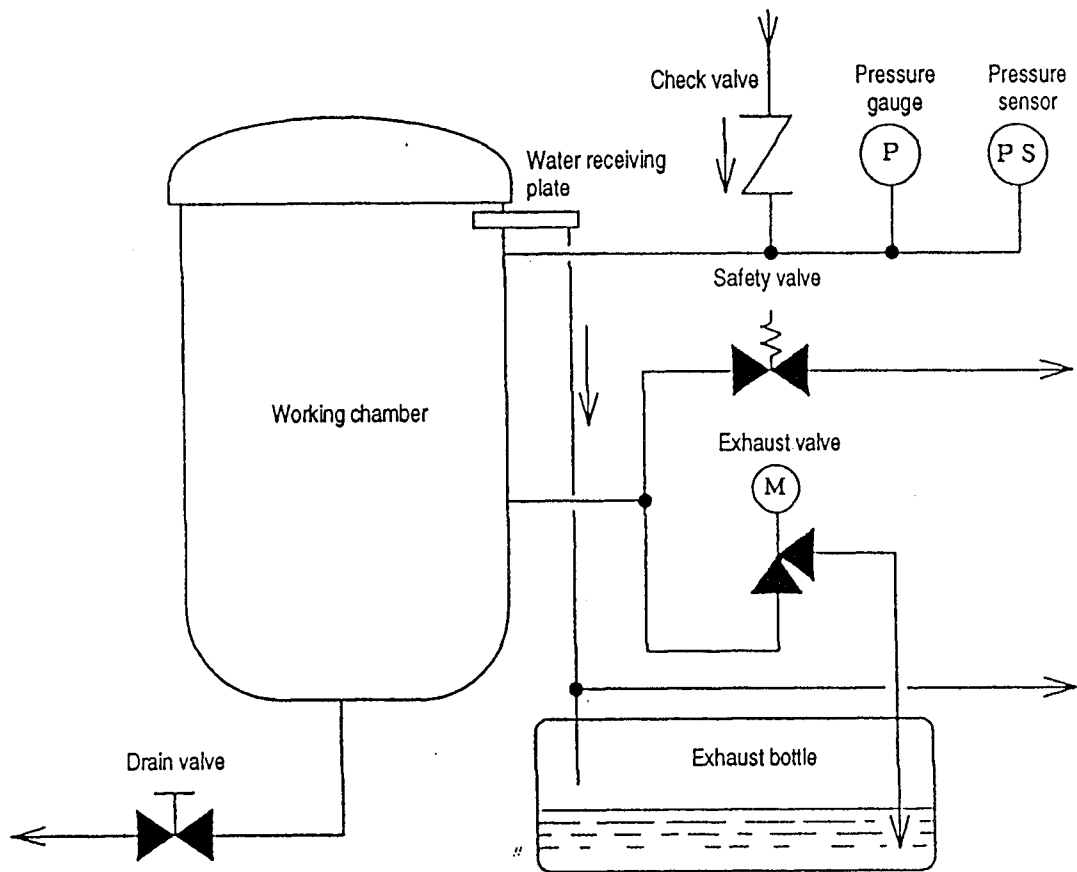

# Wiring Diagram

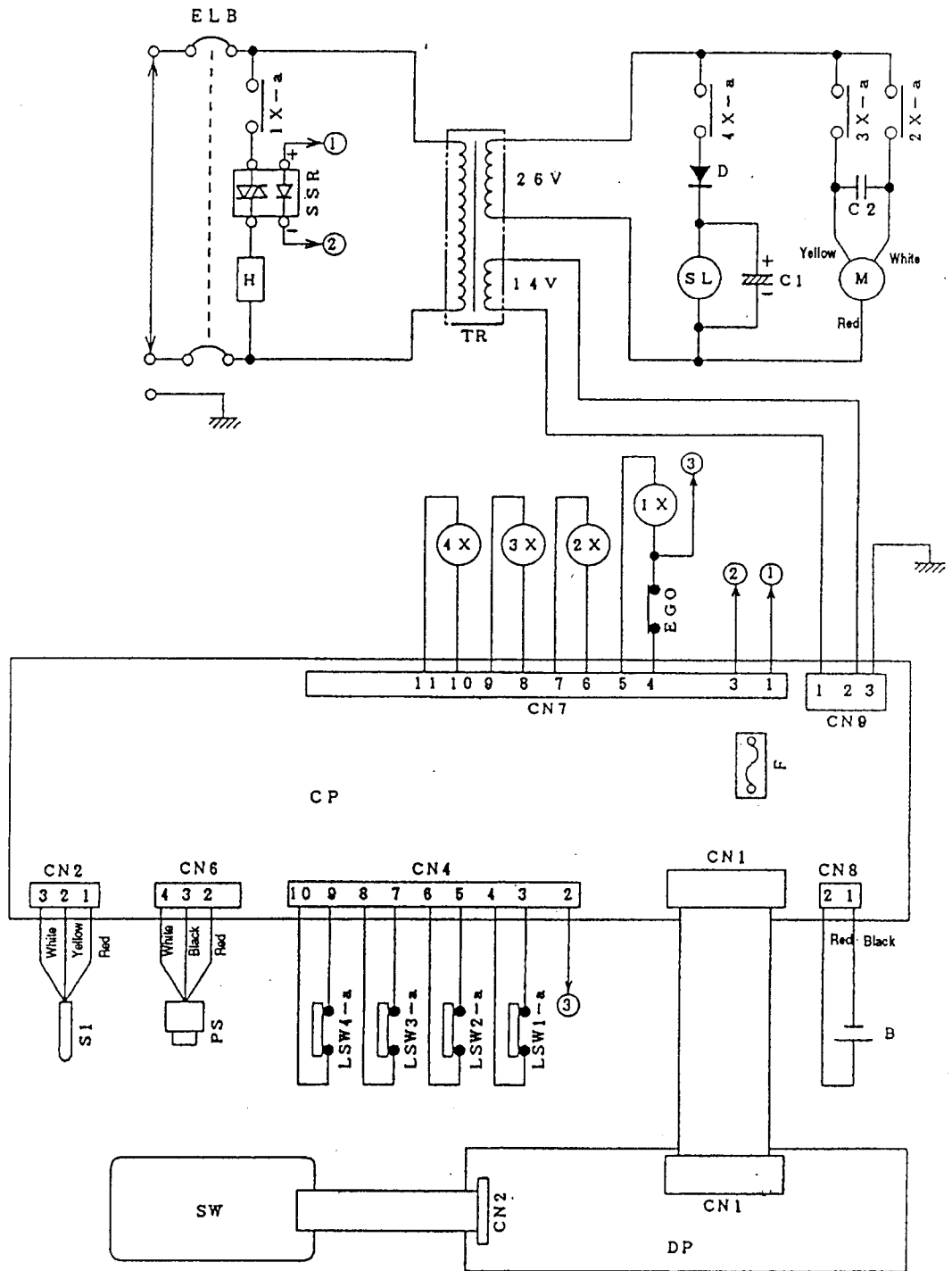

- |     |                               |      |   |
|-----|-------------------------------|------|---|
| DP  | Display printed circuit board | S1   | Temperature sensor for control          |
| CP  | Control printed circuit board | PS   | Pressure sensor                         |
| SW  | Operation switch              | EGO  | Water empty heating preventive device   |
| ELB | Power switch                  | LSW1 | Limit switch (lever open/close)         |
| TR  | Transformer                   | LSW2 | Limit switch (lever lock)               |
| F   | Fuse                          | LSW3 | Limit switch (exhaust valve full close) |
| B   | Backup battery                | LSW4 | Limit switch (bottle housing)           |
| M   | Motor                         | SSR  | Solid-state relay                       |
| C2  | Capacitor for motor           | 1X   | Relay (heater)                          |
| SL  | Solenoid                      | 2X   | Relay (exhaust valve closing)           |
| D   | Diode                         | 3X   | Relay (exhaust valve opening)           |
| C1  | Electrolytic capacitor        | 4X   | Relay (solenoid)                        |
| H   | Heater                        |      |   |



## Chapter 6. In the Event of Suspected Failure

### 1. Error Detection (Alarming) Operation

- Should any malfunction occur in your autoclave, the incorporated error detection circuit is triggered to assure your safety. Once the circuit is activated, the error number appears on the digital display, and further the electronic alarm sounds, indicating the occurrence of an abnormal condition. To stop the alarm sound, press the START/STOP switch. If an alarm is given, check the error number and turn off the power switch.

Error Number	Description of Abnormal Condition	Remedy
E r 1 (Lack-of-water alarm)	• Lack-of-water.	• Check to see that pressure is at 0 kgf/cm <sup>2</sup> , and then open the lid. After the heater has been cooled, pour in a sufficient quantity of water, and repeat operation from the beginning
	• Piping is clogged by a bag such as the waste disposal bag.	• Whenever a bag, such as a waste disposal bag, is used for sterilization, put it in the wire mesh basket and place the basket in the working chamber.
E r 2 (Temperature sensor wire breakage)	• Temperature in the working chamber falls below the freezing point.	• Adjust room temperature at the installation site to 5 - 35°C.
	• Disconnection of temperature sensor for control	• Contact the authorized sales outlet from which you purchased the product, or our service center.
E r 3 (Over temperature)	<ul style="list-style-type: none"> <li>• Temperature in the working chamber exceeds the upper limit of the working temperature range +3°C.</li> <li>• A temperature +5°C or above the set temperature continues for 10 seconds during sterilization.</li> <li>• A temperature +10°C or above the set temperature continues for 15 minutes during warming.</li> </ul>	
E r 4 (Over-cool alarm)	• A temperature of 102°C or below continued for 10 seconds during sterilization.	
E r 5 (Over-pressure alarm)	• A pressure of the saturated steam pressure at a set temperature + 0.2 kgf/cm <sup>2</sup> or above continued in the working chamber for 15 seconds.	
	• Piping is clogged by a bag such as the waste disposal bag.	• Whenever a bag, such as a waste disposal bag, is used for sterilization, put it in the wire mesh basket and place the basket in the working chamber.
E r 6 (Lid open alarm)	• The open/close lever was moved to the open side during operation.	• Contact us or the authorized sales outlet from which you purchased the product, or our service center.
E r 7 (Automatic exhaust valve trouble alarm)	• The automatic exhaust valve continued closing operation for 10 seconds.	
E r 9 (Sterilization heater trouble alarm)	• Temperature in the working chamber has not reached a set sterilization temperature when 4 hours passed after the start-up of operation.	• Reduce the quantity of a substance to be sterilized, and repeat operation from the beginning. If this error reoccurs after all measures have been taken, contact the authorized sales outlet from which you purchased the product.
E r L (Open/close lever locking failure alarm)	• The open/close lever is unlocked during operation.	• Contact the authorized sales outlet from which you purchased the product, or our service center.
E r E (Exhaust bottle anomaly alarm)	• The exhaust bottle got out of place during operation.	• Push the exhaust bottle into the housing area as far as it will go, and then repeat operation from the beginning.

## 2. Early Trouble Shooting

Symptom	Cause	Remedy
Display remains off after turning on power.	<ul style="list-style-type: none"> <li>• Check the plug and outlet first.</li> <li>(1) The plug is not properly inserted or is insufficiently tightened.</li> <li>(2) Disconnection in the power cord.</li> <li>(3) Defect in DISPLAY.</li> </ul>	<ul style="list-style-type: none"> <li>(1) Properly insert the plug. Re tighten any loose parts.</li> <li>(2)(3) Contact us or the authorized sales outlet from which you purchased the product.</li> </ul>
No air exhausted from working chamber.	(1) Defect in the automatic exhaust valve.	(1) Contact us or the authorized sales outlet from which you purchased the product.
Pressure gauge reading remains low.	<ul style="list-style-type: none"> <li>(1) Defect in the safety valve.</li> <li>(2) Defect in the pressure gauge.</li> <li>(3) Disconnection in the heater.</li> <li>(4) Defect in the automatic exhaust valve.</li> <li>(5) Steam leakage.</li> </ul>	<ul style="list-style-type: none"> <li>(1)~(4) Replace defective part with new one (Contact us or the authorized sales outlet from which you purchased the product).</li> <li>(5) In case of steam leakage from piping, re tighten or seal joints.</li> </ul>
Steam leakage from lid packing.	<ul style="list-style-type: none"> <li>(1) Deterioration in the lid gasket.</li> <li>(2) Improperly installed lid gasket.</li> <li>(3) Foreign matter under the gasket.</li> </ul>	<ul style="list-style-type: none"> <li>(1) Replace the lid gasket with new one.</li> <li>(2) Uniformly push the gasket to eliminate unevenness.</li> <li>(3) Remove the foreign matter.</li> </ul>
Water leakage from bottom of body.	<ul style="list-style-type: none"> <li>(1) Deterioration in the heater seal packing due to lack-of-water or the like.</li> <li>(2) The drain valve open.</li> </ul>	<ul style="list-style-type: none"> <li>(1) Contact us or the authorized sales outlet from which you purchased the product.</li> <li>(2) Close the valve.</li> </ul>
Open/close lever can not slide.	<ul style="list-style-type: none"> <li>(1) Temperature in the working chamber has exceeded 98°C (80°C)* or in the SOLID mode, or pressure in the working chamber has exceeded 0.1 kgf/cm<sup>2</sup>.</li> <li>(2) The power switch is off.</li> </ul>	<ul style="list-style-type: none"> <li>(1) Wait until temperature in the working chamber falls below 97°C (79°C) or in the SOLID mode and pressure is reduced to 0 kgf/cm<sup>2</sup>.</li> <li>(2) Turn on the power switch.</li> </ul>
Lid cannot be opened/closed.	(1) The open/close lever is not slid to the end of the open/close side.	(1) <b>Slide the open/close lever to the end of the open/close side.</b>
Displayed temperature exceeds set temperature and exhaust is repeated frequently during the sterilization cycle.	(1) Defect in the heater circuit.	(1) Contact us or the authorized sales outlet from which you purchased the product.

\* Specification for particular area.

- This table of early trouble shooting describes the causes of simple troubles and the remedies for them. If you find difficulty in remedying or repairing them, contact the sales outlet from which you purchased the product, and inform them of the following information:

- (1) Model and serial number of your autoclave,
- (2) Defective point(s) and symptom(s) (and error number if applicable),
- (3) Number of days of operation (date of purchase), and
- (4) Operating conditions (including substances being sterilized).

### Temperature-Pressure Conversion Table for Saturated Steam in Autoclave

The following data are approximate values for practical use in all autoclaves:

Temperature		Pressure Gauge Reading	
(°C)	(°F)	kg/cm	lb/inch
109	228	0.35	5.0
110	230	0.5	7.1
115	239	0.7	10.0
120	248	1.0	14.2
121	250	1.1	15.6
126	260	1.5	22.0
132	270	1.9	27.0
135	283	2.1	30.0

## SPARE PARTS FOR HV- AND HVE-SERIES AUTOCLAVES

<b>Catalog No.</b>	<b>Description</b>
ATA-25LG	Lid gasket for HV/HVE-25
ATA-50LG	Lid gasket for HV/HVE-50
ATA-85LG	Lid gasket for HV-85/110
ATA-25H	Heater for HV/HVE-25, 1.5KW (specify 120V or 220V)
ATA-50H	Heater for HV/HVE-50, 2KW (specify 120V or 220V)
ATA-85H	Heater for HV-85, 3KW, 220V
ATA-110H	Heater for HV-110, 4KW, 220V
ATA-HVEGO	Low water power cut-off device, includes sensor and thermostat for HV and HVE series
ATA-HVEROM	EPROM including extractor for HVE-series
ATA-HVESV	Solenoid valve for HVE-series
ATA-HVROM	EPROM including extractor for HV-series
ATA-HVPB	Plastic exhaust bottle for HV/HVE series
ATA-MTS	Thermistor sensor for MW, HV, & HVE series
ATA-MWSSR	Solid state relay for MW, HV, & HVE series
ATA-PS	Pressure sensor for HV-series
ATA-SVA	Solenoid valve assembly for HV-series
ATA-TRTP	Thermal paper for digital recorder, 9 rolls

